

Pack Out Process for Off-Form Concrete

Preparation Process

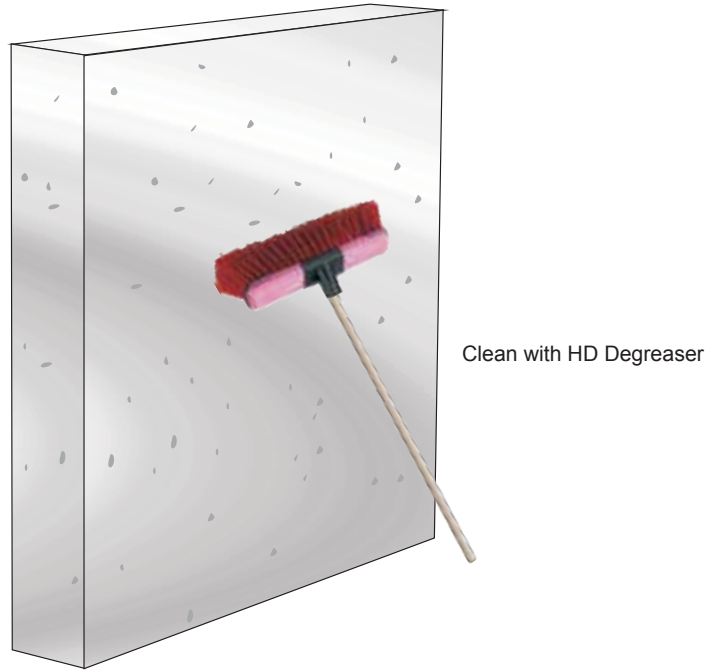

3 steps pack out process prior to application of the render system

Blowholes and Imperfections in wall surface

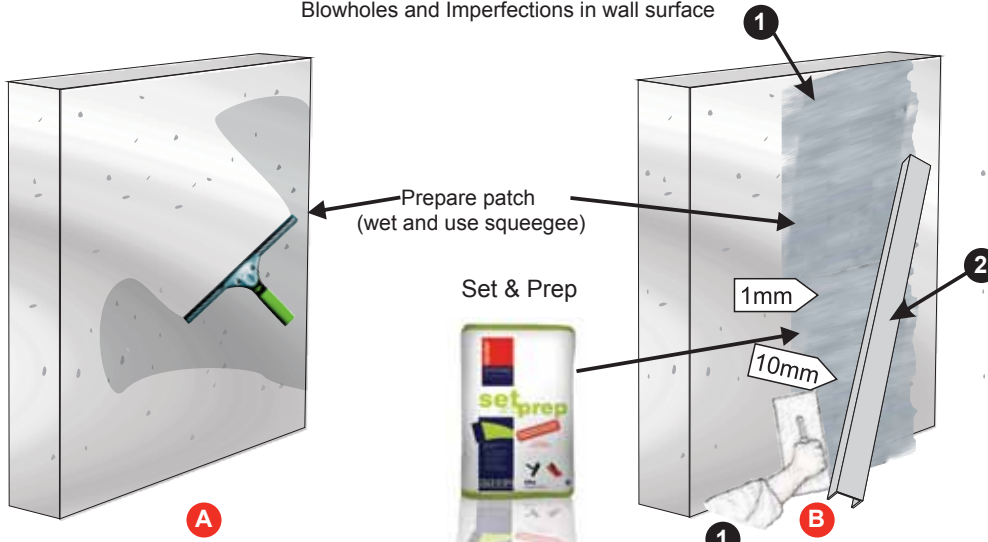

Set & Prep

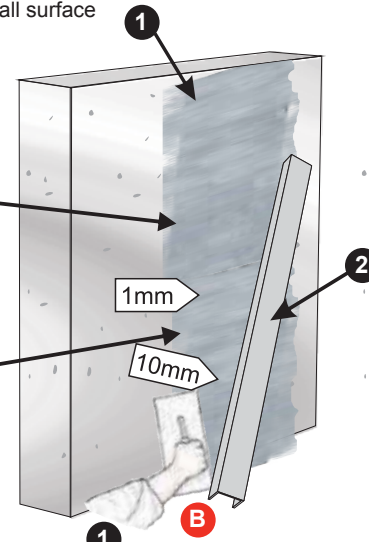

Add 10% by volume of GP cement powder. Use within 30 minutes of mixing



- A** Mix Patch Fine
 - B** Whilst stirring add 10% by volume of GP Cement
 - C** If required add water for ease of trowelling
- Note: Mix required volume only for specific area
Use within 30mins of mixing

15L
Patch Fine

RSA offers a 7 Year Product Warranty provided:-

1. All substrates are installed in accordance with manufacturer specifications, Australian Standards and Good Trade Practices.
2. All products and processes as detailed above are applied by an RSA preferred contractor and in accordance with RSA Data Sheets, Application Information and Good Trade Practices. For further information visit: www.render systemsaustralia.com.au or Tel. (07) 3287 6444
We reserve the right to alter the above specifications at any time, without prior notice.
3. Guidelines Only – Please refer to RSA Product Data Sheets and Application Guidelines